

NCSIMUL



YOUR COMPANY NEEDS

MACHINING SIMULATION

You use complex NC machine-tools and are looking for a way to boost your company's productivity:

- By reducing the time spent on debugging your NC programs
- By preventing the risk of collisions and tool breakage
- By optimising your cutting conditions and thereby reducing machining time

NCSIMUL embodies our knowledge and understanding of the manufacturing environment and its machinery, and is today's most sophisticated solution for machining simulation in all companies, from large corporations to small, independent workshops.

THE BENEFITS

- ROI in just 6 months
- Reduced proving time on the machine, yielding higher productivity rates
- Fewer dry runs means shorter schedules
- No more broken machine components
- Short training cycle (1 or 2 days)
- Reduced machining time

Instead of using your machine-tools to fine-tune your NC programs, save them for the real task of part production.

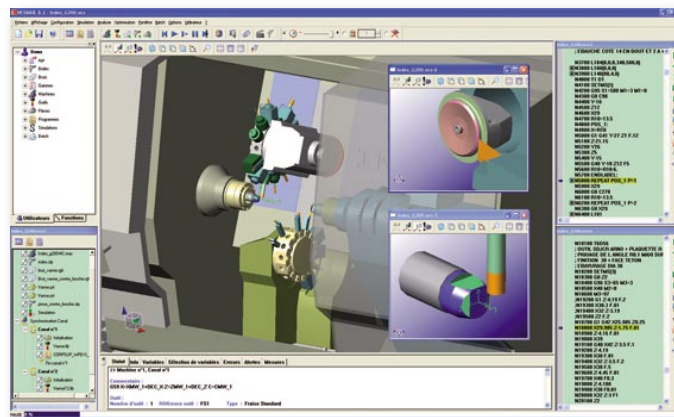

Simulation of a mill-turn centre (2 turrets, 2 spindles)

NCSIMUL'S SPECIAL FEATURES

- ISO decoding and machine simulation at the heart of the product
- Windows native user interface with OpenGL 3D technology
- Interactivity between 3D simulation, ISO program and information windows
- Tool path display and error detection before machining simulation
- Realistic 3D simulation of machine motion and material removal with dynamic zoom and rotation of the full view
- Universal Machine Technology supporting all possible kinematics (parallel kinematics, multi-turret, multi-spindle, pallet changer, flexible assembly line) and an unlimited number of axis
- Integrated graphics editor to create new machines (NCMOTION)
- Optimisation of cutting conditions

NCSIMUL, THE PROFESSIONAL SOLUTION FOR DEBUGGING YOUR NC PROGRAMS IN FOUR STEPS

1 ANALYSIS OF THE NC PROGRAM

- ISO decoding (5 to 10 MB/min) supporting structured programs, variables, cycles, macro calls, with an unlimited choice of commercially available NC controllers
- Tool path preview before simulation; rapid first-level analysis (incorrect program origin, etc.)
- Automatic detection of programming errors (ISO syntax, out-of-range motion, compensation errors, etc.)
- Integrated ISO program editor for on-line modification
- Precise and reliable estimations of cycle times

2 MATERIAL REMOVAL AND MACHINE SIMULATION

- Material removal on a solid model for all types of machining
- Total simulation of the «machine-part pair» with detection of all collision types in a single process
- Detection of machining errors (rapid motion, spindle stopped, part marked, etc.)
- 3D viewing operations (rotate, zoom, pan) independent of program size, or the complexity of the part or program

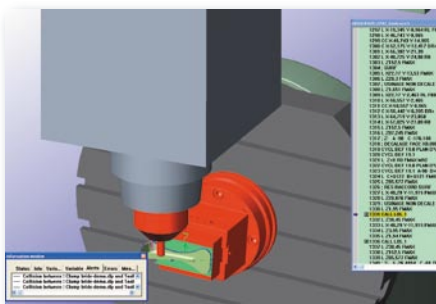

Detection of a tool/clamp collision

3 DIMENSIONAL ANALYSIS

- Dimensional analysis of the part (thickness, point coordinates, curvature, drilling, internal turning diameter, list of points, etc.)
- Quick, precise comparison between the machined part and the original CAD model
- Dynamic 3D cross-section and exported 2D cross-section

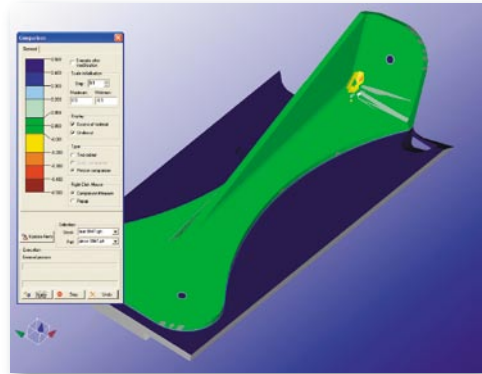

Solid model comparison between the machined rough stock and the original CAD model

4 ANALYSIS AND OPTIMISATION OF CUTTING CONDITIONS

- Analysis of cutting parameters for each section in a block
- Generation of alarm logs based on user-defined criteria (e.g.: maximum cut depth, etc.)
- Optimisation of approach and retract motion (air cutting reduction)
- Optimisation of cutting parameters according to the tool-material pair
- Display of the tool path based on feeds
- Graphic comparison between the initial program and the optimised program
- Rewriting of the ISO program based on optimal feeds and spindle rotations to be used during machining

NCSIMUL, A «DIGITAL WORKSHOP» SOLUTION

With 25 years' experience in the PLM, SPRING Technologies has gained worldwide recognition in the field of manufacturing industry with its «DIGITAL WORKSHOP» offering of software and services accompanying the leading products on the CAD/CAM and PDM markets.



www.springplm.com